



# Regina Wood Cook Stove

## USE AND INSTALLATION MANUAL



OMNI report number: 0528WS003S

LISTED TO STANDARDS:  
UL 1482-2011 (R2015)  
ULC S627-00

Cod. 90002832 Rev.1



<b>1.FOREWORD AND MAIN FEATURES</b> .....	<b>3</b>
1.1                    TECHNICAL DATA COOK STOVE REGINA .....	4
<b>2. PACKAGING</b> .....	<b>5</b>
<b>3.TRANSPORT AND INSTALLATION</b> .....	<b>5</b>
<b>4.IMPORTANT INFORMATION</b> .....	<b>5</b>
<b>5.EXHAUSTS EVACUATION</b> .....	<b>7</b>
5.1                    POSITIONING AND CONNECTION TO THE FLUE .....	7
5.2                    FLUE AND CHIMNEY POT.....	7
5.3                    PROTECTION OF THE FLOOR .....	9
5.4                    SECURITY DISTANCES .....	9
<b>6.COMBUSTIBLE</b> .....	<b>10</b>
<b>7.....IGNITION</b> .....	<b>11</b>
7.1                    AIR FOR COMBUSTION .....	12
<b>8.MAINTENANCE</b> .....	<b>13</b>
8.1                    DAILY MAINTENANCE.....	13
8.2                    USE OF THE ASHES .....	13
8.3                    PERIODICAL MAINTENANCE .....	13
8.4                    CLEANING OF THE GLASS OF THE HEARTH DOOR .....	14
8.5                    REGULATION OF THE HANDLE .....	14
8.6                    BROKEN GLASS REPLACEMENT .....	15
<b>9.PROBLEM SOLVING GRID</b> .....	<b>16</b>
<b>10.SPARE PARTS</b> .....	<b>18</b>
<b>11.WARRANTY</b> .....	<b>21</b>
<b>12.NOTES</b> .....	<b>28</b>

## ***SAVE THESE INSTRUCTIONS***

***The authority having jurisdiction (such as municipal building department, fire department, fire prevention bureau, etc.) should be consulted before installation to determine the need to obtain a permit.***



## 1. FOREWORD AND MAIN FEATURES

**The owner or the end user authorized to the use of the combustion device is obliged to keep the Technical Documents and to exhibit them upon request of the competent authorities.**

**All local regulations, including the ones referring to national and European norms, shall be respected when installing the cook stove.**

Lincar cook stoves are manufactured with top-quality materials, produced with state-of-the-art techniques and technologies, and checked and controlled by specialized technicians in order to exploit at its best the energy of wood.

The main features of REGINA are:

- Hearth of cast iron, built by composed and jointed elements.
- Hearth door with ceramic glass, resistant to high temperatures.
- Ash drawer, removable when the fire is ignited.
- Manually adjustable primary and secondary air.
- Grid-shaker, usable from the outside.
- Heating by natural convection.
- Better thermic performance by using the heat of the fumes, which are conveyed in forced passages.
- Cast-iron cooking plate with removable rings.
- Cast-iron hearth and oven doors.
- Additional glass on door for **children safety**.
- Inox handle and knobs.
- Thermometer for oven.
- Oven grid and dripping pan.

**Read this manual carefully before setting the cook stove in operation, so as to better know and appreciate its features and characteristics.**

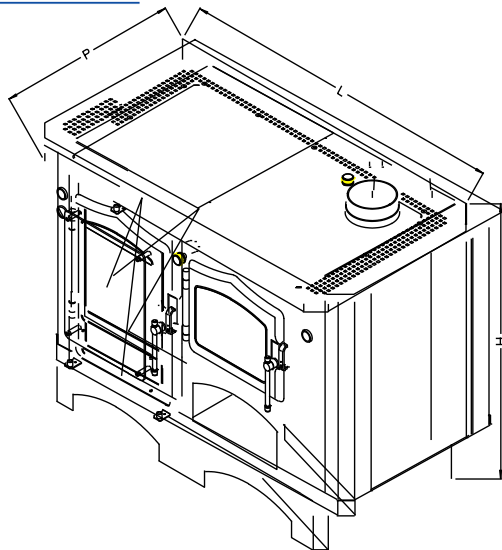

Figure 1

<b>1.1 TECHNICAL DATA COOK STOVE REGINA</b>		
Height	<b>mm</b>	920
Length	<b>mm</b>	1250
Depth	<b>mm</b>	670
Weight	<b>kg</b>	260
Diameter fumes exhaust	<b>mm</b>	156 (6.125")
Nominal output power	<b>kW</b>	10
Performance	<b>%</b>	75
Heating volume	<b>m<sup>3</sup></b>	230
Average consume	<b>Kg/h</b>	3,6
Maximum permitted load	<b>Kg/h</b>	4
Minimum draught required	<b>Pa</b>	10
CO measured with 13% of oxygen at the nominal heat output	<b>%</b>	0.10
Temperature of exhausts	<b>°C</b>	209
Minimum safety distance from flammable objects	<b>mm</b>	200

## 2. PACKAGING

The packaging of your cook stove is designed to protect it against possible damages. Nevertheless, it could happen that the cook stove and/or the accessories could have suffered from damages during transportation.

We recommend checking, immediately upon delivery, for missing components or damages to the cook stove and signalling immediately any irregularity to your retailer.

**The packaging of your cook stove is made of environment-friendly material.**

## 3. TRANSPORT AND INSTALLATION

The cook stove shall be lifted using the appropriate rings welded into the structure. The cook stove shall be installed on a floor having an adequate loading capacity. If not the case, proper means shall be undertaken (e.g., load distribution plate). Should the floor be made of wood, it is advisable to use a protective plate that should distribute the weight. It is extremely important to keep safe distances from flammable objects, especially in respect to the exhaust pipe. When this room heater is not properly installed, a house fire may result. To reduce the risk of fire, follow the installation instructions. Contact local building or fire officials about restrictions and installation inspection requirements in your area.

## 4. IMPORTANT INFORMATION

**All local regulations, including the ones referring to national and European norms, shall be respected when installing the cook stove.**

- Before starting the cook stove, read carefully and entirely this manual.
- Use only means with sufficient loading capacity for transport and handling of your cook stove.
- Do not use the cook stove as an element of support.
- The combustion of fuel releases thermal energy, causing a relevant warming of the cook stove surface, the doors and their handles, regulation knobs, glasses, the exhaust pipes and possibly also the rear part of the cook stove. Any contact with those zones shall be avoided without proper means of protection, like thermal protected gloves or thermal isolated handling systems.
- Never use the cook stove as an incinerator or for any other use than the purpose for which it has been designed.
- Children shall be clearly made aware of the dangers and kept far from the cook stove during operation.
- It is forbidden to lay a non-heat-resistant object on the cook stove or in its surroundings.
- It is forbidden to lay or handle on the top of the cook stove any recipient containing hot water or liquid without proper means of protection, in order to avoid serious burns.
- It is forbidden to dry clothes or any other item on the cook stove.
- Supports for drying clothes or similar shall be kept at a reasonable distance in order to avoid fires.
- During the operation of the cook stove, it is forbidden to handle flammable or explosive substances in the room or in nearby areas.
- Do not use flammable liquids to start the cook stove.
- For safety reasons against fire, it is advisable to keep a powder extinguisher of min. 3 kg at hand.
- In case of fire in the flue, the following operations are advised:
  - Absolutely do not detach the cook stove from the exhaust pipe.
  - Immediately call the Fire Department.
- Avoid the risk of hits to glasses and doors.

- Do not start the cook stove if glasses are scratched or broken.
- Avoid opening the door to clean the glass while the cook stove is operating. This operation shall be done only when the cook stove is off.
- Hot ashes in the ash chamber shall be removed using the provided tools and stored in a well-closed clay or metal recipient. The recipient shall be laid on a non-combustible surface (marble floor or surface, tiles, etc.) and away from flammable items until cold, then can be disposed of.
- Never make unauthorized modifications to the cook stove.
- Use only original spare parts, recommended by the manufacturer.
- Never use the cook stove with open or half-open door: excessive temperature may result causing severe burns or nearby object damages.
- Open the door only for adding wood and using the appropriate protection gloves supplied with the cook stove; close the door immediately afterwards.
- Due to the wide dimension of the hearth, pay particular attention when adding wood when flames are rather lively. An abrupt opening of the door could cause flames to come out from the cook stove. Do not wear easily flammable clothes.
- The cook stove is equipped with a supplementary tempered glass to be positioned on the door, so as to constitute a good protection against heat exposure of the legs when cooking. **(Figure 2)**
- Opening and closing while fuel loading may result in a small amount of smoke being emitted. It may be necessary to arrange locations of smoke detectors to prevent bothersome false alarms.

**CAUTION:** Do not adopt any make-shift compromises during the installation process.

**WARNING:** DO NOT INSTALL IN BEDROOMS.

**CAUTION:** THE STRUCTURAL INTEGRITY OF THE FLOOR, WALL, AND CEILING/ROOF MUST BE MAINTAINED.

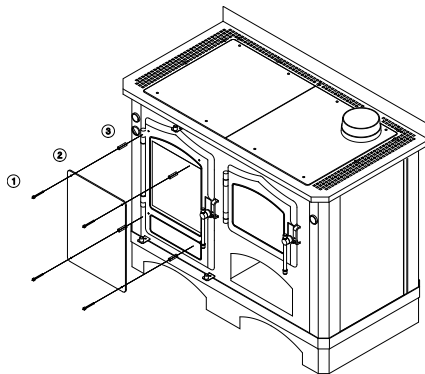

**Figure 2**

## 5. EXHAUSTS EVACUATION

The pipes for the evacuation of exhausts represent a source of danger, both for fires or the outpouring of toxic gases. Great caution shall be paid when the exhaust pipe is connected to the flue with walls or parts of them made of wood.

When joining the pipe to the flue, the former shall never overlap into the flue (**Figure 3**) and the connection shall be properly sealed.

The correct operation of the cook stove is granted exclusively by a good draught of the flue. The minimum value to be granted at **1 meter** of distance from the exit on the collar of the plate shall be **>10 Pa**. These instructions are requested in order to avoid the generation of carbon monoxide and the possible hazards from carbon monoxide.

In case of bad weather conditions (phenomena of thermal inversion), pay particular attention to the emission of fumes and gases and to the conditions of the draught.

In cases of incorrect feeding of the cook stove or lack of air for combustion, the room could fill with smoke or unburned gases could come out. In that case, let the fire burn down and check for eventual occlusions in the pipes and check the cleanness of the pipes. When the pipes are already partially occluded, the formation of deposits on the pipes and into the flue increases rapidly and jeopardizes its optimal function.

### 5.1 POSITIONING AND CONNECTION TO THE FLUE

For a correct operation, the cook stove shall be installed in the proximity of the flue. The connection between cook stove and flue shall be as short as possible, in order to avoid annoying problems of condensation in the pipes and, in any case, an anomalous operation of the cook stove itself.

When performing the connection, it is advisable:

- Avoid an excess of bends (no more than two). (**Figure 5**).
- Avoid long segments of horizontal pipe (max 30% of the whole vertical length). (**Figure 5**)
- Incline the horizontal segments by 10-15% towards the flue to ease the evacuation of the fumes. (**Figure 5**)
- Try to have the vertical section of the pipe superior to 1.5 m. (**Figure 5**)
- Absolutely avoid that the metal pipe overlaps into the flue. (**Figure 3**)
- Properly seal the connection point between pipe and flue.
- Use, in conformity with the current safety norms, pipes of adequate thickness and with a diameter compatible with the collar supplied with the cook stove.
- **DO NOT CONNECT THIS UNIT TO A CHIMNEY FLUE SERVING ANOTHER APPLIANCE.**

### 5.2 FLUE AND CHIMNEY POT

The flue is essential for a good operation of any solid fuel heating device. The depression, commonly known as draught, is related to the height of the flue, which shall never be inferior to **five meters**, with a section of at least 20x20 cm. It is important that the flue has no narrowing or air infiltrations that could reduce the correct operation.

The minimum value of the depression to be granted at **1 meter** of distance from the exit of the collar on the plate shall be **at least 10 Pa**. With inferior values, the flame will be weak with formation of soot and bad for the pipes, causing a possible exit of smoke from the door when loading wood, as well as very low efficiency.

It is important that the flue serves only one cook stove. If several pipes should converge in the same flue, the draught will be irregular, with consequences on the good operation of the cook stove.

If the latter condition is compulsory, the pipe shall be extended into the flue, until a sufficient draught could be restored. (**Figure 5**)

A good draught can be checked by igniting a piece of paper at the base of the exhaust pipe. If the draught is good, the flame will be attracted with strength towards the inside. The cook stove is equipped with a cast-iron chimney connector.

**CAUTION:** Flues positioned outside the house or in cold environments shall be protected and insulated.

The chimney pot is highly relevant for a good operation of the cook stove, and shall be executed in a way that the exit of the smoke shall take place at least 100 cm (**Figure 4**) higher than any other structure in a radius of 10 meters, including the vault of the roof.

The surface of the loopholes shall not be inferior to the section of the flue.

**BURN UNTREATED WOOD ONLY. OTHER MATERIALS SUCH AS WOOD PRESERVATIVES, METAL FOILS, COAL, PLASTIC, GARBAGE, SULPHUR, OR OIL, MAY DAMAGE THE CATALYST.**

- This room heater must be connected to a chimney complying with the requirements for Type HT chimneys in the Standard for Chimneys, Factory-Built, Residential Type and Heating Appliance, UL 103.
- The size of the chimney shall be 6 inches and type of the chimney should be UL-103HT.
- The chimney must be suitable for solid fuel, and shall be a code-approved masonry chimney with a flue liner.
- Please read this entire manual before you install and use your new room heater. Failure to follow instructions may result in property damage, bodily injury, or even death.
- Never use gasoline, gasoline-type lantern fuel, kerosene, charcoal lighter fluid, or similar substance to “freshen up” a fire in this heater. Keep all such liquids well away from the heater while it is in use.
- The chimney connector shall not pass through an attic or roof space, closet or similar concealed space, or a floor or ceiling. Where passage through a wall, or partition of combustible construction is desired, the installation shall conform to CAN/CSA-B365, *Installation Code for Solid-Fuel-Burning Appliances and Equipment*.
- **WARNING:** Chimney and chimney connector must be in good condition and kept clean!

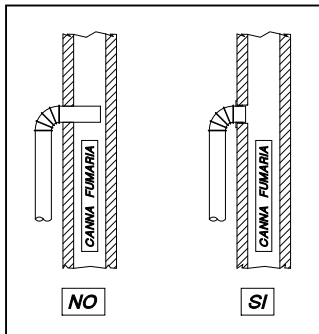

**Figure 3**

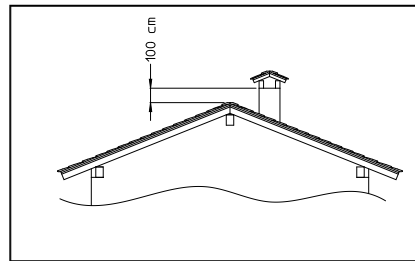

**Figure 4**

Chimney Connector size to be used: 24 ga black or blued-steel, 6-inch diameter. The standard requires that the chimney connector be attached to the collar by at least two fastening screws. Requires a code-approved masonry chimney with a flue liner with a 6-inch diameter (15.24cm). The wood-burning cook stove appliance must be installed in accordance with the applicable local laws or the CAN/CSAB365, NFPA211 (USA) norms. Follow the chimney manufacturer's instructions to install the chimney. This appliance must be connected to a 6-inch (15.24 cm) factory-built chimney HT UL 103 or CAN/ULC S629-compliant or a 6-inch (15.24 cm) masonry chimney with a homologated sleeve inside.



### 5.3 PROTECTION OF THE FLOOR

The cook stove shall be installed on a floor having an adequate loading capacity. If not the case, proper means shall be undertaken (e.g., load distribution plate).

The cook stove shall be laid on a non-flammable floor. Should the floor be made of wood or covered with carpet, a refractory support base (steel plate or similar) shall be installed so that it overlaps at least 50 cm from the opening of the door and at least 30 cm from the sides of the cook stove. The minimum total area has to be 2.5 square meters.

- 1) Minimum area under the cook stove is 2.5 sq.mt.
- 2) There should be 16 inches (406 mm) beyond the front and 8 inches (203 mm) beyond each side of the fuel loading and ash removal openings.
- 3) The area under the chimney connector shall be 2.5 sq.mt and 2 inches (50.8 mm) beyond each side.

Item 3 in the requirements refers to the floor under any horizontal run of chimney connector pipe.

### 5.4 SECURITY DISTANCES

Great care shall be taken when connecting the exhaust pipe to the flue, using safety fixations and pipes of adequate thickness and diameter, and taking into account the existing regulations.

When kindling the cook stove for the first time, check the position of the wood-stopper.

Figure 5

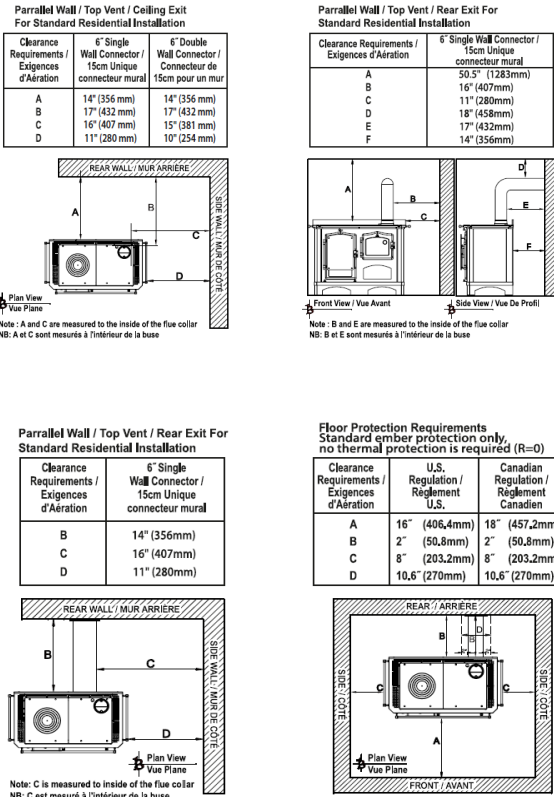

The installation shall grant an easy access to the cook stove, to the exhaust pipe and to the flue for cleaning operation. Clearances may only be reduced by means approved by the regulatory authority.

With these reduced clearances, this appliance takes a minimum of space where it is installed. Whether in the living room or the dining room, the cook stove will complete your decor with its originality and heating. It requires a minimum clearance of 12 inches to the back (for a smoke simple pipe with a heat shield) and an 18-inch lateral MINIMUM clearance.

In the case of a smoke simple pipe without a heat shield, you must install the cook stove so that the smoke pipe is to 18 inches of all combustible material; therefore, the minimum clearance at the back of the stove will be 16¼ inches (41.28 cm).

For a 45° corner installation, or other corner installation, the minimum clearance between the cook stove and combustible material must be 18 inches.

## 6. COMBUSTIBLE

The cook stove is designed to burn **dry wood in logs** (relative humidity <15%) or logs of pressed wood. Never burn plastic materials, painted and varnished wood, chipboard panels and coal. The incorrect use of combustibles could cause the development of toxic substances and damage both the cook stove and the flue. With a correct combustion process, the emitted carbon-dioxide corresponds to the quantity emitted naturally by the felled trees and by the undergrowth; therefore, the combustion is 100% ecological. **(Figure 7)** One layer of wood shall be loaded on a bed of embers, one at a time, so as to avoid the risk of overheat.

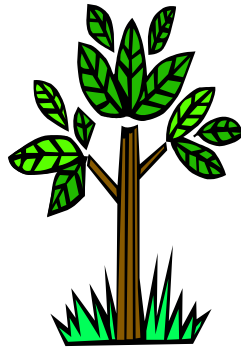
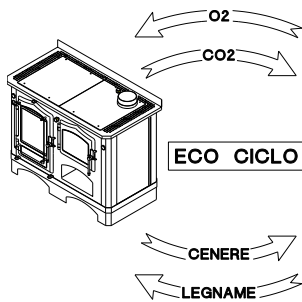

Figure 7

## WARNINGS:

It is advised, during the first ignitions, to bring the cook stove gradually in temperature, in order to enable all components to experience a progressive temperature increase and adjustment to dilatation.

A regular maintenance by a qualified technician is necessary at least once a year.

A new cook stove requires the complete drying of the paint and of the metallic inner parts.

During the first kindling, ensure a sufficient aeration in the room, so as to evacuate the vapours or fumes that are generated. That inconvenience disappears after a few kindlings.

Use exclusively solid fuel as wood in logs, pressed wood logs or bricks of lignite.

NEVER USE any type of coal, wood scraps containing paint or varnish or glues that could cause serious problems of toxic emissions.

**DO NOT OVERFIRE THE COOK STOVE.** Check the maximum permitted load on page 4.

The thermal power indicated in this notice represents the maximum limit of use of the cook stove; therefore, any load of combustible superior to the indications can compromise the duration of the materials and of the cook stove itself, but also compromise the warranty.

## 7. IGNITION

**All local regulations, including the ones referring to national and European norms, shall be respected in installing the cook stove.**

In order to obtain a quick and correct kindling of the cook stove, follow accurately the instructions below:

1. If the cook stove and flue are cold, or the atmospheric pressure is low, burn at first some pages of a newspaper.
2. Open the primary air intake 1, the secondary air intake 3, and the grid 2, then turn the supplementary draught lever 4 on position A. **(Figure 8)**
3. Put into the hearth some balls of newspaper, then a layer of wood chips and, on top, a layer of bigger wood (max 1.5 kg).
4. Set fire to the paper, close the door and, once a good combustion has been reached, close the primary air intake 1 by acting on the lever.
5. The emission of secondary air into the combustion chamber, regulated by the lever 3, happens through a pre-heating duct that sends it to brush the wide glass bay of the door, cooling and cleaning it.
6. In all cases, the lever 3 for secondary air regulation, in closed position, enables anyway a minimal air flow, in order to avoid any phenomenon of gasification of the fuel.
7. The ash drawer is positioned underneath the grid, and shall be emptied regularly. It is very important to pay attention to the fact that the ashes could still contain some burning embers. Therefore, ashes shall be collected in inflammable containers.
8. The ash-shaker grid is moved by shaking the lever 2 to and fro. In the "open" position, there is passage of primary air, regulated only by the lever 1.

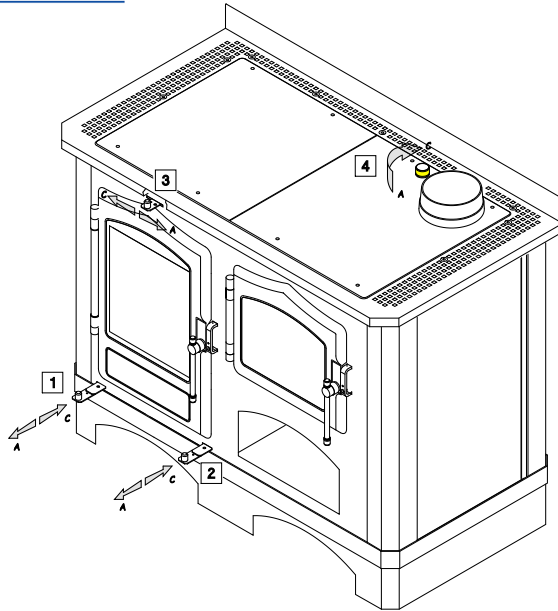

Figure 8

**REGINA:**

**Nominal operating conditions, to which the performances indicated for the device refer, involve primary air (1), hearth grid lever (2) and kindling valve (4) closed, secondary air (3) open by half, 3.41 kg of wood burned in 1 hour (length between 20-25 cm) and draught of the chimney flue equal to 12 Pa.**

In order to obtain a slow combustion, reduce to the minimum the primary air flux and the secondary air flux by using the above-mentioned levers. It is in any case imperative that each flue have its own draught and, given the latter is quite sensitive to the climatic variations, to fine-tune each lever in order to obtain an optimal combustion. The grids dedicated to air intake shall be kept clean and free from any obstruction.

**CAUTION:** Do not alter damper adjustment range for increased firing for any reason!

**7.1 AIR FOR COMBUSTION**

The process of combustion requires intake of primary air. In the case of free-standing cook stoves, the necessary air for combustion is taken from the surrounding environment. It is therefore necessary to remember to re-integrate the level of oxygen in the room by providing a regular change of air. In modern houses, with isolated door and window frames, the air circulation is limited. The situation gets worse with the presence of other devices that consume air in the room.

Thus, it is advised to install a permanent air intake close to the cook stove (i.e., direct outside venting grill of a minimum 10x10 cm size) or, in any case, in the room where the cook stove is installed.

## 8. MAINTENANCE

In order to preserve in time the efficiency of the cook stove and the integrity of the inner parts (hearth, oven), it is important to execute a correct daily and periodical maintenance.

All maintenance and cleaning operations shall be executed only when the cook stove has completely cooled down.

It is important to underline that the use of wood with a low grade of humidity reduces the interventions of cleaning and maintenance and, on the contrary, the use of inappropriate combustible can reduce the duration of the cook stove.

The annual inspection from a qualified technician is highly advised.

### 8.1 DAILY MAINTENANCE

Remove the ashes and make them fall in the appropriate ash-drawer by using the ash-shaker grid lever. The ashes can be used as a plant fertilizer.

Using a cloth and appropriate products, it is possible to clean the ceramic glass of the hearth door and the eventual protection glass.

The excess of soot on the ceramic glass of the hearth indicates a lack of draught of the flue that could, in some cases, be caused by the use of wood with excess of humidity.

Clean the outer part of the cook stove using only a wet cloth.

**NEVER USE ABRASIVE PRODUCTS OR SPONGES that could damage the paint coating.**

Should repairs to the paint be necessary, appropriate spray cans are available.

### 8.2 USE OF THE ASHES

The rest of the combustion is composed by the mineral elements of the wood (about 1-2%) that accumulate in the ash box. Those ashes are a natural product and a good fertilizer for all kinds of garden plants.

Ashes should be left to rest and then "extinguished" with water.

### 8.3 PERIODICAL MAINTENANCE

Establish a routine for the fuel, wood burner, and firing technique. Check daily for creosote build-up until experience shows how often you need to clean to be safe. Be aware that the hotter the fire, the less creosote is deposited, and weekly cleaning may be necessary in mild weather, even though monthly cleaning may be enough in the coldest months. Contact your local municipal or provincial fire authority for information on how to handle a chimney fire. Have a clearly understood plan to handle a chimney fire. After the winter period use or when a diminution of the draught is perceived, it is advised to execute a thorough cleaning of the cook stove. In particular, attention shall be paid to the exhaust pipe to the connection to the flue. Check also the tightness of the joints.

To operate as above, follow the instructions:

1. Remove the pipe and the cast iron collar.
2. Thoroughly clean the upper part with a brush or a swab from the fumes ring hole.
3. When necessary, remove the plate by unscrewing the upper screws. (**WARNING:** Before removing the plate, remove the flag valve on the side of the fumes ring by pulling upwards the knob while holding the flag through the fumes exit. Once the cleaning is performed, re-assemble the flag proceeding in reverse.)
4. Clean the whole hearth.
5. Remove soot and incrustations from the upper part of the oven, from its sides, and from the bottom (passing through the fumes exit).

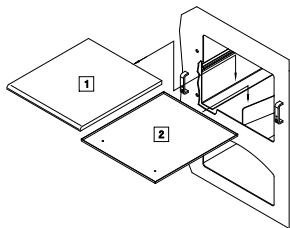

**Figure 9**

6. Access the part underneath the oven (fumes channel) removing first the soapstone 1 and then the metal plate 2 (**Figure 9**), and aspire the dust and residuals.
7. Check the cleanness of the flue, intervening if necessary.
8. Clean off soot and incrustations from the connection pipe to the flue.
9. Reassemble the cast-iron cooking plate, taking care to position the washer correctly on the contact edge.
10. Reassemble the connection pipe to the flue.

#### **8.4 CLEANING OF THE GLASS OF THE HEARTH DOOR**

The best way to clean the glass of the hearth door is to use a wet cloth. Persistent dirt can be removed with a special detergent, available by your retailer.

**WARNING:** Never clean the glass when it is still hot.

#### **8.5 REGULATION OF THE HANDLE**

In order to prevent air losses through the door towards the inner part of the hearth, it is possible to act both on the regulation of the hinges and on the wedge of regulation of the closing handle, thus obtaining a better compression of the washer. (**Figure 10**)

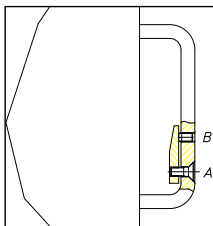

**Figure 10**

**WARNING: NEVER OPERATE COOK STOVE WHEN THE GLASS IS BROKEN OR CRACKED.**

Replace only with a 4 mm ceramic glass with the right shape. **DO NOT USE SUBSTITUTE.**

Steps to replace glass:

- 1) Loosen partially the screws retaining the four glass supports and remove the support. (On the oven door, remove the screw completely.)
- 2) Remove the broken glass and all pieces of broken glass. Clean the door.
- 3) Stick the flat fiberglass rope around the glass without pulling it excessively. A sticking side is already on the flat rope.
- 4) Install the new glass and put the lower support first and gently tighten screw. Tightening it too much can create a pressure point and break the glass when it becomes too hot.
- 5) Install the top support and gently tighten screw.
- 6) Check the tightening. Tightening it too much can create a pressure point and break the glass when it becomes too hot.

If you cannot replace the glass in place, you may have to remove the door to do it. Look in this manual for instructions.

## 9. PROBLEM SOLVING GRID

Problem	Cause	Solution
Soot covers the glass too quickly	Insufficient draught	Either clean the flue or make it longer.
	Incorrect regulation of the air intake	Regulate the air intake according to the instructions of the manual. For long periods, at the minimum, the glass dirties itself more rapidly but part of the soot burns and is removed once a correct regulation reached.
	Humid wood	Use, as an alternative, pressed wood logs or wood with humidity inferior to 15%.
The cook stove does not operate in a regular way	Insufficient draught of the flue	Check the draught.
	Soot deposits on the inside of the cook stove	Follow the cleaning indications of the manual.
The combustible does not burn in a regular way	Unfavourable weather conditions	
	Insufficient draught of the flue	Check the draught.
	Wrongful kindling process	Check the "ignition" paragraph.
The cook stove emits smoke	The cook stove is dirty	Follow the cleaning indications of the manual.
Smoke output when adding wood	Insufficient draught of the flue, the exhaust is not tight	Check the connections, the joints and the cleanness.

### **FURTHER DIRECTIONS:**

#### *"Creosote – Formation and Need for Removal"*

When wood is burned slowly, it produces tar and other organic vapors, which combine with expelled moisture to form creosote. The creosote vapors condense in the relatively cool chimney flue of a slow-burning fire. As a result, creosote residue accumulates on the flue lining. When ignited, this creosote makes an extremely hot fire.

The chimney connector and chimney should be inspected at least once every two months during the heating season to determine if a creosote buildup has occurred. If creosote has accumulated, it should be removed to reduce the risk of a chimney fire.

Establish a routine for the fuel, wood burner, and firing technique. Check daily for creosote build-up until experience shows how often you need to clean to be safe. Be aware that the hotter the fire, the less creosote is deposited, and weekly cleaning may be necessary in mild weather even though monthly cleaning may be enough in the coldest months. Contact your local municipal or provincial fire authority for information on how to handle a chimney fire. Have a clearly understood plan to handle a chimney fire.

#### *"Disposal of Ashes"*

Ashes should be placed in a metal container with a tight-fitting lid. The closed container of ashes should be placed on a noncombustible floor or on the ground, well away from all combustible materials, pending final disposal. If the ashes are disposed of by burial in soil or otherwise locally dispersed, they should be retained in the closed container until all cinders have thoroughly cooled.

Store the fuel (wood logs) in a dry and vented place. Do not use humid or wet wood logs.

A source of fresh air into the room or space shall be provided when required.

It is necessary to keep firing and de-ashing doors closed and to maintain all seals in good condition.





**FURTHER CAUTIONS:**

- DO NOT CONNECT TO OR USE IN CONJUNCTION WITH ANY AIR DISTRIBUTION DUCTWORK UNLESS SPECIFICALLY APPROVED FOR SUCH INSTALLATIONS.
- DO NOT USE CHEMICALS OR FLUIDS TO START THE FIRE.
- DO NOT BURN GARBAGE OR FLAMMABLE FLUIDS SUCH AS GASOLINE, NAPHTHA OR ENGINE OIL.
- HOT WHILE IN OPERATION. KEEP CHILDREN, CLOTHING AND FURNITURE AWAY. CONTACT MAY CAUSE SKIN BURNS.
- DO NOT OPERATE WITH BROKEN GLASS.
- DO NOT BUILD THE FIRE TOO CLOSE TO THE GLASS.
- BURN UNTREATED WOOD ONLY. OTHER MATERIALS SUCH AS WOOD PRESERVATIVES, METAL FOILS, COAL, PLASTIC, GARBAGE, SULPHUR, OR OIL, MAY DAMAGE THE CATALYST.

**FURTHER WARNINGS:**

- **GLASSES:** Do not use substitute materials, and do not abuse glass doors such as striking or slamming shut.
- **COMPONENTS:** Do use all specified components and nothing other than specified components.
- Do not operate with the firing doors open.
- Keep wood at a distance of 36 inches (91cm) or more.
- Do not place fuel within the space heater installation clearances or within the space required for charging and ash removal.
- Fires must be made directly on the firebox floor and shall not be elevated with grates.

## 10. SPARE PARTS

<i>Pos.</i>	<i>Description</i>
05	Disc-shaped grid
06	Grid holder
07	Hearth side
08	Fumes ring
09	Cooking plate frame
10	Ash drawer
11	Wood-stopper
12	Hearth door glass
13	Hearth door
18	Hearth door handle
20	Hearth door washer
27	Knob for lever
33	Hearth door glass washer
34	Hearth brick 48x295

<i>Pos.</i>	<i>Description</i>
35	Hearth brick 100x345
42	Oven soapstone
43	Oven door
44	Oven door washer
45	Glass washer
46	Oven door handle
47	Oven door glass
48	Oven thermometer
52	Protection glass
54	Plate washer
55	Oven-side plate
56	Hearth-side plate
57	Rings for plate



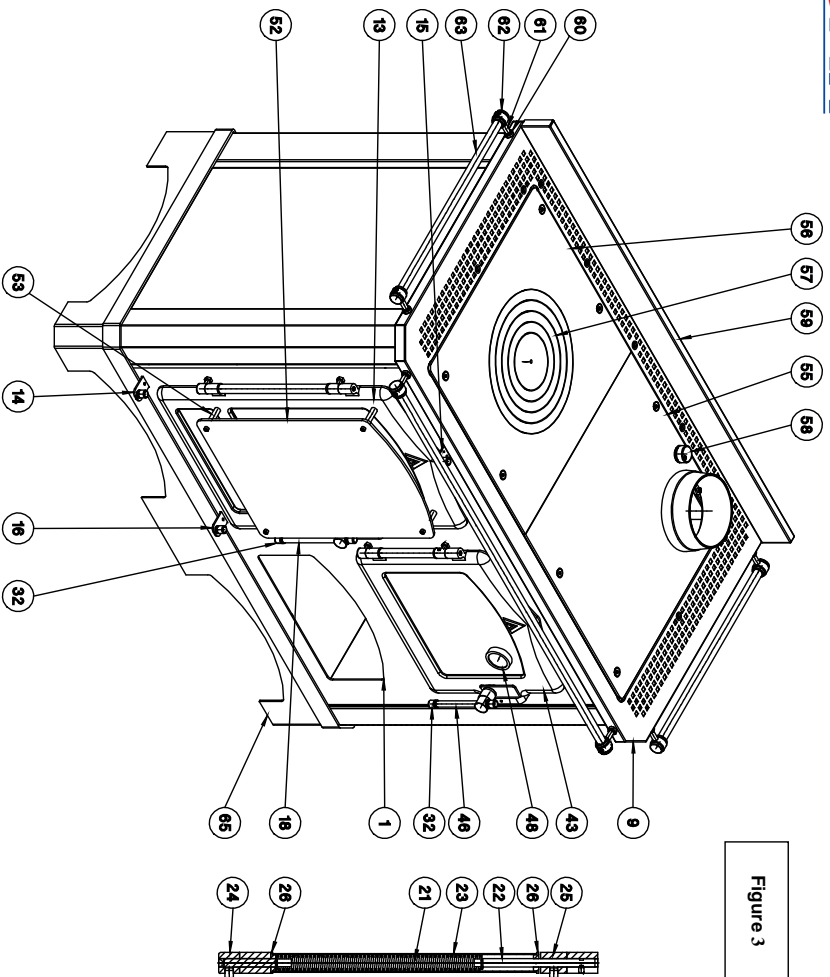

Figure 3

## 11. WARRANTY

Lincar reminds you that as manufacturer of this product, it is the holder of the rights set forth by Law by Decree no. 24, dated 2 February 2002, and that the warranty below leaves these rights unchanged.

This warranty certificate, issued by Lincar, with registered headquarters in Dronero (CN), Via 1° Maggio no. 14, concerns all the components of the stove supplied with the Lincar brand and is extended to the free repair and/or replacement of them, provided that:

- The fault arises within 2 years from the purchase of the product and is notified to the retailer and/or Lincar Service Centre within 2 months from noting it; and
- It is acknowledged as such by a Lincar Technical Service Centre.

The Lincar Service Centre, after ascertaining the validity of the warranty certificate and legal purchase invoice/receipt, will not charge any cost for the operations carried out and the components replaced.

### First FREE ignition and test (pellet products only):

- Lincar SRL provides the end user a **free first ignition** and test service by a Lincar Service centre, with the purpose of checking that the product is working properly and that installation is carried out according to current regulations.
- The failure to avail of this service could bar the validity of the warranty.
- The Lincar Service Centre will also provide all the information for correct use and maintenance of the product.

## WARRANTY TERMS OF VALIDITY

### The warranty is acknowledged as valid, provided that:

- The stove is installed according to current regulations on the subject, adhering to the instructions contained herein and by a professionally skilled technician/retailer.
- The warranty certificate has been duly completed in all its parts and then confirmed by the retailer or authorised Lincar Service Centre.
- The warranty certificate, together with the invoice/receipt, are kept and shown to the Lincar Service Centre in the event of warranty service.

### The warranty is not acknowledged as valid in cases in which:

- Installation fails to comply with the instructions given herein and in accordance with current regulations on the subject.
- The above-mentioned warranty terms of validity have not been met.
- The presuppositions exist of the customer's negligence due to the lack of or incorrect product maintenance and/or improper use of it.
- Electric/plumbing systems are noted, which fail to meet current regulations and are unsuitable for the correct installation and operation of the product.
- Damage is found caused by atmospheric, chemical or electrochemical agents, tampering, alterations or improper use of the product, inadequacy of the flue and any other cause not deriving from product manufacturing.
- Damage is found caused by corrosion or deposits typical of heating systems (for hydro products).
- Maintenance operations have been carried out and there has been replacement of Lincar components with non-OEM ones by technical personnel not authorised by Lincar.
- A fuel is used other than the one specified for correct operation and/or of poor quality (pellets and wood).
- At the time of receiving the product, all damages caused by transport and/or incorrect handling of the product by the forwarder are not claimed immediately, noting them on the shipping document.

Lincar SRL is not responsible for any damage that may be directly or indirectly caused to persons, property or pets due to the failure to adhere to the instructions contained herein and listed previously.

**The warranty excludes:**

- Seals, ceramic or toughened glass, claddings, plates, cast iron grills and hearth modules, painted, chromium-plated or gilded parts, majolica cladding.
- Any imperfections of majolica, stone or marble claddings (such as cracks, streaks, salts, marks, changes of shade), which are inherent in the materials themselves and not classifiable as defects or indicative of poor quality.
- Masonry and installation works and the materials needed for them.
- The parts of the system for producing sanitary water (hydro products).
- The heat exchanger if an adequate anti-condensation circuit is not made and the specifications for correctly doing so contained herein are not followed (hydro products).
- Any calibration or adjustments of the product in relation to the type of fuel or alteration of the type of installation.

**Further clauses:**

- For products sold abroad the same warranty terms remain valid, on an ex-factory basis, with the exception of particular conditions agreed upon during negotiations with the foreign distributor.
- In the case of part replacements, the warranty is not extended.
- Materials in stock c/o retailers are considered with warranty suspended until the actual date of sale to the end user. During this period, it is the retailer's responsibility to store the products in suitable places and ways in order to ensure their perfect state of preservation.

**Warranty service operation:**

**The request for a warranty service operation must be forwarded to the pertinent LincAR Retailer or Service Centre.**

**Liability:**

**LincAR does not acknowledge any compensation for direct or indirect damages caused by or depending on the product.**

**Competent tribunal:**

For any dispute, the competent tribunal is the court of Cuneo.

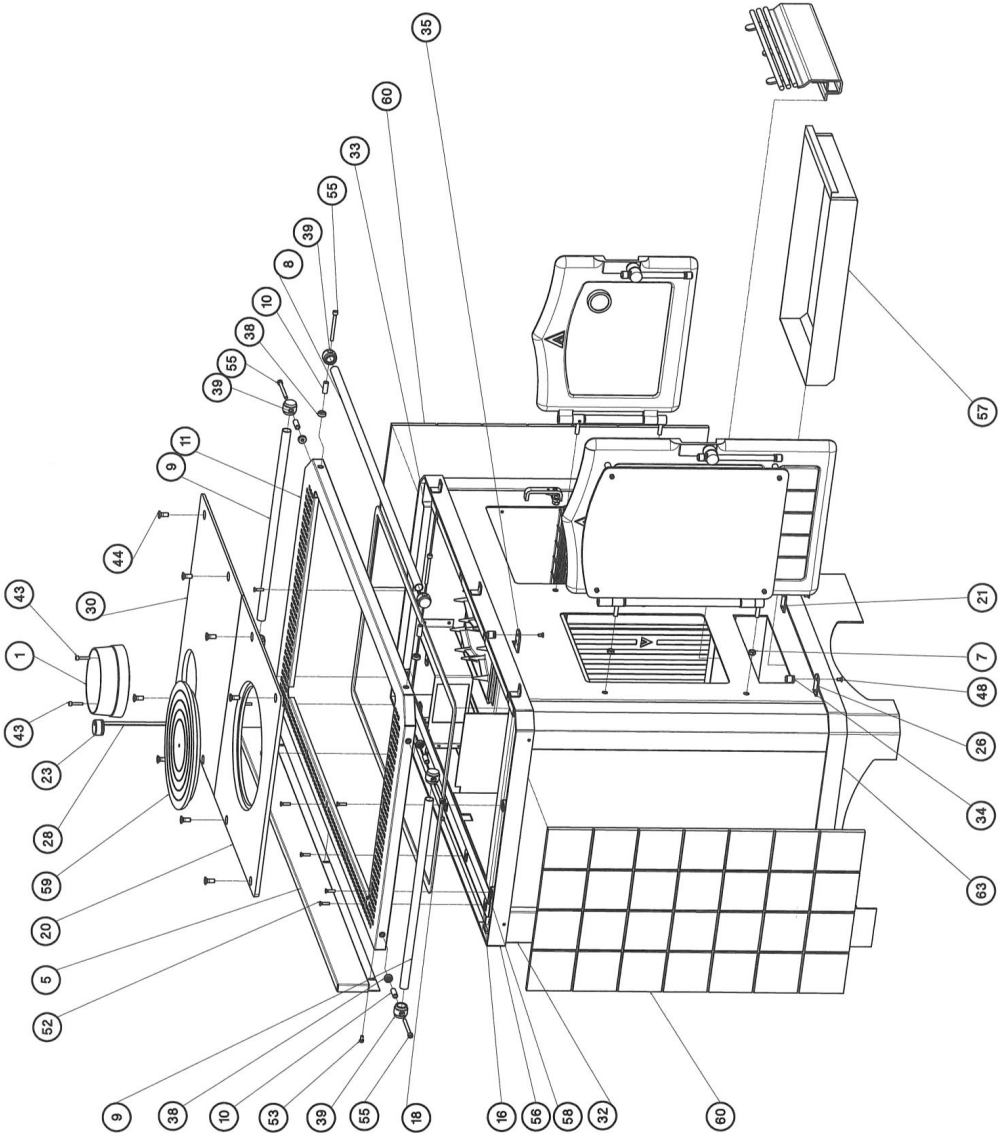

	<p><b>WOOD-BURNING COOK STOVE REGINA</b></p>	<p><b>8.5.2 INSIDE FIREPLACE AND OVEN</b></p>
--	--	---

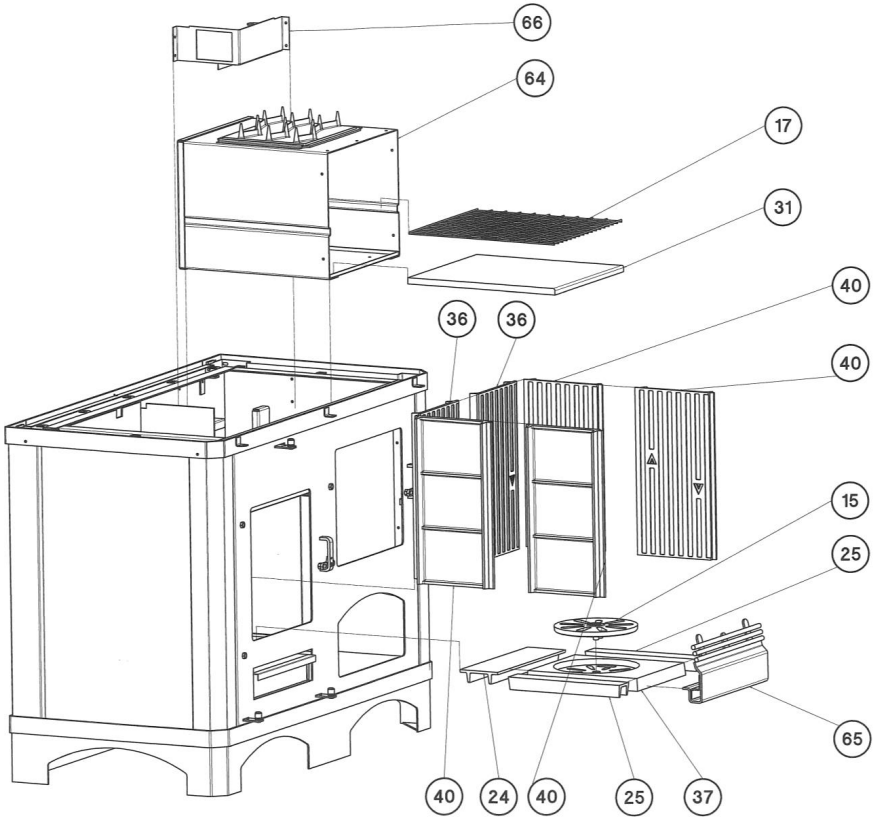



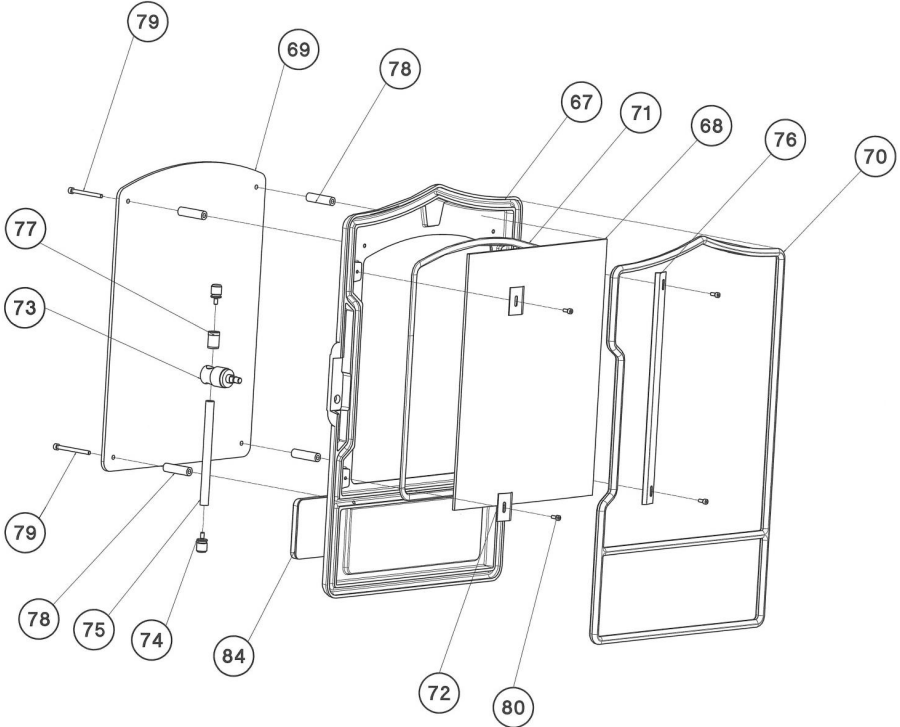

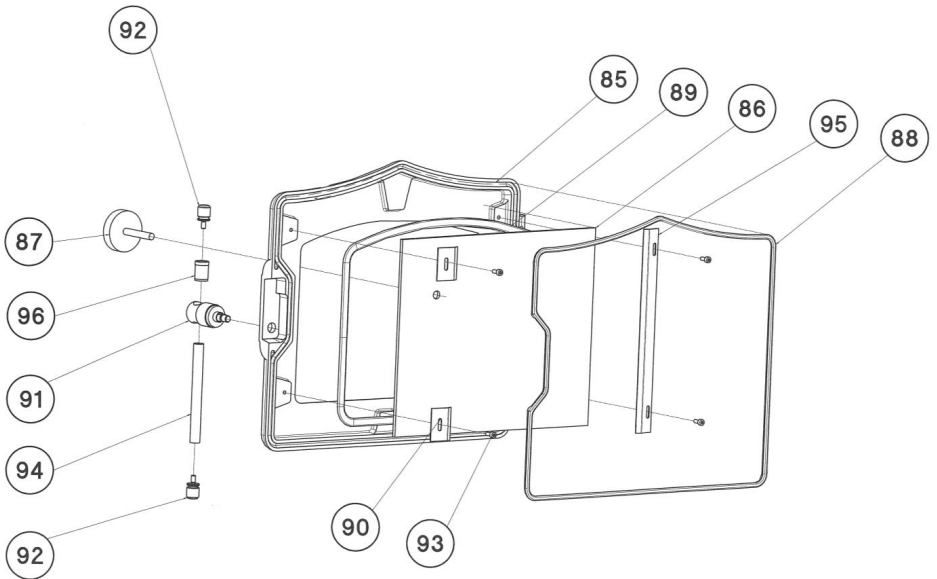

Nr.	NAME	QTY	CODE	PAGE
1	FLUE RING	1	1610100211	3
5	REAR SHELF	1	00204385	3
7	NUT	4	1610800207	3
8	FRONT BANISTER	1	1611801152	3
9	SIDE BANISTER	2	1610801149	3
10	SPACER FOR BANISTER	6	1610801146	3
11	STAINLESS STEEL PLATE FRAME	1	1610204384	3
15	GRILL	1	1610100214	4
16	REAR PANEL	1	00200510	3
17	OVEN GRILL	1	1611508417	4
18	FLAT GASKET	1	16109NIN20	3
20	SIDE FIREPLACE PLATE WITH CIRCLES	1	1610102017	3
21	OPEN/CLOSE LEVER FOR GRILL	1	00201214	3
23	KNOB WITH ROTATION OF STARTING VALVE	1	1610801213	3
24	FIREPLACE SURFACE CASTING 100x345x30	1	1610100937	4
25	FIREPLACE SURFACE CASTING 48x295x30	2	1610100936	4
26	PRIMARY AIR LEVER	1	00200603	3
28	ROTATION STARTING VALVE PIN	1	00200522	3
30	SIDE OVEN PLATE	1	1610100378	3
31	OVEN SOAP STONE	1	1610500295	4
32	LEFT SIDE	1	00200509	3
33	RIGHT SIDE	1	00204226	3
34	HANDLE KNOB	3	1610800201	3
35	SECONDARY AIR LEVER	1	00200502	3
36	FIREPLACE CASTING 200x400	2	1610105516	4
37	GRILL HOLDER	1	1610100213	4
38	BANISTER WASHER	6	1610801583	3
39	BANISTER END	6	1610801143	3
40	FIREPLACE CASTING 200x400	4	1610100873	4
43	SCREW TCI CROCE M5x25 ZN UNI7687	2	0950106732	3
44	SCREW	8	0950105856	3
48	SCREW TCEI M5x8 UNI 5931 DIN 912	3	0950105631	3
52	SCREW AUTOF ø4.2 L 25 TSP UNI6955_ZN	9	0950606237	3
53	SCREW TCI CROCE M5x10 ZN UNI7687	5	0950105925	3
55	SCREW TCEI M6X60 INOX UNI5931 DIN912	6	0950106130	3
56	UPPER BAND	1	00200511	3
57	ASH DRAWER	1	00200292	3
58	STRUCTURE	1	002005161	3
59	PLATE RINGS	1	1610101804	3
60	SIDE PANEL	2	1610508315	3
63	BASE	1	002005151	3
64	OVEN ASSEMBLY	1	002048701	4
65	LOG STOPPER	1	16103060001	4
66	FLUE FUNNEL	1	00200507	4
67	DOOR WITH PROTECTING GLASS	1	1610103005	5
68	CERAMIC GLASS	1	1610700221	5
69	PROTECTING GLASS	1	1610700747	5
70	DOOR GASKET	1	1610800220	5
71	GLASS GASKET	1	16109NIN84	5
72	GLASS-STOP CLAMP	2	1610303615	5
73	HANDLE KNOB	1	1610800198	5
74	HANDLE KNOB	2	1610800200	5
75	HANDLE	1	1610800202	5
76	GLASS-STOP CLAMP	1	1610303618	5
77	INSULATING BUSHING FOR HANDLES	1	1610801166	5
78	PROTECTING GLASS SPACER	4	1610800613	5
79	SCREW TCEI M5x55 UNI5931 DIN912	2	0950105630	5
80	SCREW TCEI M4X8 UNI 5931 DIN 912	4	0950105744	5
84	FRONTAL PLATE	1	1610508317	5
85	STOVE DOOR	1	1610103008	6
86	OVEN GLASS HOLDER	1	1610700300	6
87	THERMOMETER	1	161077R500	6
88	OVEN DOOR GASKET	1	16109TIN12	6
89	GLASS GASKET	1	16109NIN84	6
90	GLASS-BLOCK CLAMP	2	1610303615	6
91	HANDLE KNOB	1	1610800198	6
92	HANDLE KNOB	2	1610800200	6
93	SCREW TCEI M4X8 UNI 5931 DIN 912	4	0950105744	6
94	OVEN HANDLE	1	1610800289	6
95	GLASS-BLOCK CLAMP	1	1610303619	6
96	INSULATING BUSHING FOR HANDLES	1	1610801166	6



CORISIT SRL, Via E Fermi 5, Reggiolo (RE) 42046 Italy

T. +39 0522 972260

**info@corisit.com**

[www.corisit.com](http://www.corisit.com)